

# IMPROVEMENTS TO HANCE ROAD AND COONEY TERRACE - PHASE 2

## NEW JERSEY DEPARTMENT OF TRANSPORTATION TRUST FUND

### BOROUGH OF FAIR HAVEN MONMOUTH COUNTY, NEW JERSEY OCTOBER 2021

PUBLIC UTILITIES	
<b>ELECTRIC</b>	
JERSEY CENTRAL POWER & LIGHT ONE RIVER CENTRE 331 NEWMAN SPRINGS ROAD, BLDG. 3 RED BANK, NEW JERSEY 07701	(732) 212-4246
<b>GAS</b>	
NEW JERSEY NATURAL GAS COMPANY 1415 WYCKOFF ROAD WALL, NEW JERSEY 07719	(732) 938-1000
<b>WATER</b>	
NJ AMERICAN WATER COMPANY 661 SHREWSBURY AVENUE SHREWSBURY, NEW JERSEY 07702	(732) 933-5924
BOROUGH OF REDBANK 75 CHESTNUT STREET REDBANK, NEW JERSEY 07701	(732) 530-2770
<b>TELEPHONE</b>	
VERIZON 5100 BELMAR BLVD. FARMINGDALE, NEW JERSEY 07727	(732) 751-8718
<b>CABLE</b>	
COMCAST CABLE COMPANY 403 SOUTH STREET EATONTOWN, NJ 07724	(732) 542-8107
<b>SEWER</b>	
TWO RIVERS WATER RECLAMATION AUTHORITY 1 HIGHLAND AVENUE MONMOUTH BEACH, NEW JERSEY 07750	(732) 229-8578
LOCATION OF UTILITIES SHOWN ON THE PLANS ARE PLOTTED FROM AVAILABLE DATA ON FILE WITH THE UTILITY COMPANIES AND ARE NOT WARRANTED AS TO EXACTNESS. CONTRACTOR IS TO DETERMINE EXACT LOCATION AND DEPTH OF UTILITIES AT ALL CROSSINGS PRIOR TO CONSTRUCTION IN ACCORDANCE WITH THE REQUIREMENTS OF THE CONTRACT DOCUMENTS.	

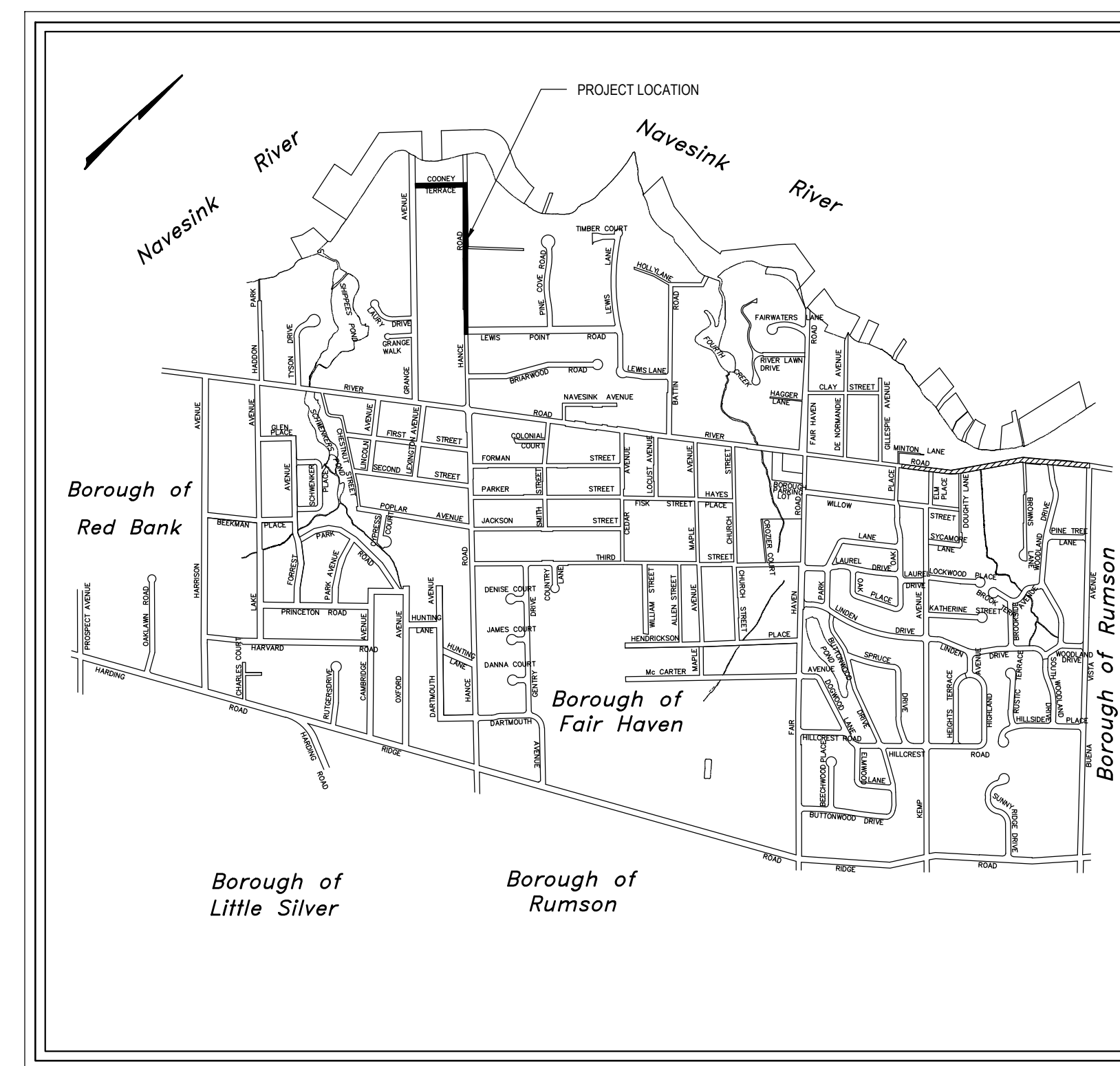

SHEET INDEX	
1	TITLE SHEET AND LOCATION PLAN
2	LEGEND, NOTES, AND CONTRACT QUANTITIES
3 - 4	CONSTRUCTION PLANS
5	CONSTRUCTION DETAILS
6	TRAFFIC CONTROL PLAN AND NOTES

NJDOT STANDARD ROADWAY CONSTRUCTION - TRAFFIC CONTROL - BRIDGE CONSTRUCTION  
DETAILS BOOKLET AND STANDARD SPECIFICATIONS (2019) SHALL GOVERN FOR THIS PROJECT.

<b>TITLE SHEET AND LOCATION PLAN</b>			
<b>IMPROVEMENTS TO HANCE ROAD AND COONEY TERRACE - PHASE 2</b>			
	BOROUGH OF FAIR HAVEN 748 River Road, Fair Haven, NJ 07704 phone: 732.747.0241 fax: 732.747.6962 website: www.fairhavennj.org	Scale: AS NOTED	Project No. 21-03
	RICHARD GARDELLA, PE, PP, CME, CPWM PROFESSIONAL ENGINEER New Jersey License No. 43747	DATE: 10/25/2021	Drawn by: RG
		Designed by: RG	Sheet Number: <b>1</b> of 6

**STANDARD LEGEND**

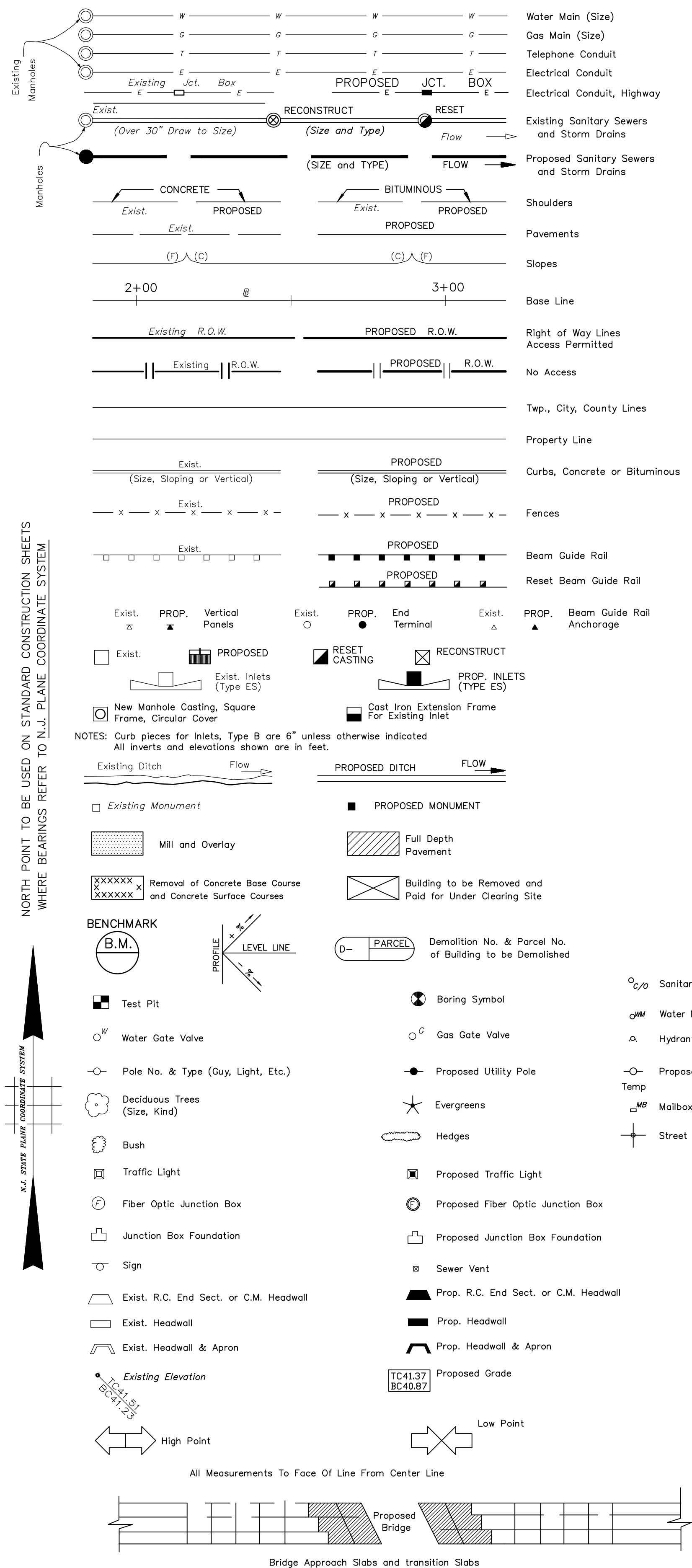

**BID ITEMS AND QUANTITIES**

Item No.	Description	Unit	Quantity
1	CLEARING SITE	LS	1
2	PRE-CONSTRUCTION VIDEO	LS	1
3	INLET FILTER, TYPE 1	SF	30
4	BREAKAWAY BARRICADE WITH SIGN	UN	8
5	CONSTRUCTION SIGNS	SF	25
6	DRUM	UN	10
7	TRAFFIC CONE	UN	40
8	TRAFFIC DIRECTOR, FLAGGER	HR	400
9	REMOVE AND RESET BRICK PAVEMENT WALKWAY	SY	15
10	RECONSTRUCT MASONRY STEPS	LS	1
11	CONCRETE DRIVEWAY, REINFORCED, 6" THICK	SY	35
12	BELGIUM BLOCK DRIVEWAY	SY	10
13	REMOVE AND RESET BRICK PAVEMENT DRIVEWAY	SY	20
14	8"x18" CONCRETE VERTICAL CURB	LF	1,525
15	GRANITE CURB	LF	15
16	HOT MIX ASPHALT DRIVEWAY, 2" THICK	SY	100
17	GRAVEL DRIVEWAY	SY	15
18	HOT MIX ASPHALT MILLING, 0'-3" DEPTH	SY	5,800
19	HOT MIX ASPHALT MILLING, VARIABLE DEPTH	SY	300
20	SUPERPAVE HOT MIX ASPHALT SURFACE COURSE (2")	TON	750
21	HOT MIX ASPHALT BASE COURSE	TON	75
22	DENSE GRADED AGGREGATE (6")	TON	50
23	TACK COAT	GAL	400
24	RESET EXISTING CASTING	UN	12
25	RESET WATER VALVE BOX	UN	6
26	RESET GAS VALVE BOX	UN	6
27	INLET, TYPE 'B'	UN	9
28	MANHOLE	UN	2
29	RECONSTRUCT MANHOLE	UN	2
30	MANHOLE FRAME AND COVER	UN	4
31	HDPE PIPE, 15" DIAMETER	LF	140
32	HYDRO-JETTING STORM DRAIN PIPE, 24" DIAMETER	LF	1750
33	REGULATORY AND WARNING SIGN	SF	50
34	TRAFFIC STRIPES, THERMOPLASTIC, 4"	LF	250
35	EXCAVATION, TEST PIT	CY	10
36	TREE REMOVAL, UP TO 12" CAL. DBH	UN	1
37	TREE REMOVAL, OVER 12" CAL. DBH	UN	1
38	TOPSOILING (4" THICK)	SY	1100
39	SODDING	SY	1100

**GENERAL NOTES:**



- LIMIT OF PAVING, THE CONTRACTOR SHALL SAWCUT OR MILL STRAIGHT LINE AS DIRECTED BY THE ENGINEER TO MEET EXISTING.
- INSTALLATION OF SURFACE COURSE SHALL NOT BE ALLOWED UNTIL THE BASE COURSE IS APPROVED BY THE ENGINEER. THE ENGINEER WILL DIRECT THE CONTRACTOR TO MAKE CORRECTIVE MEASURES TO THE BASE COURSE PRIOR TO INSTALLING THE SURFACE COURSE. ALL COSTS FOR CORRECTIVE WORK, IF ANY, SHALL BE INCLUDED IN THE VARIOUS ITEMS IN THE PROPOSAL.
- NO SEPARATE PAYMENT SHALL BE MADE TO SAWCUT EXISTING PAVEMENT, DRIVEWAYS, OR SIDEWALKS, INCLUDE ALL COSTS IN THE VARIOUS ITEMS IN THE PROPOSAL.
- HOT MIX ASPHALT BASE COURSE AREAS SHALL BE PARALLEL TO THE ROADWAY CENTERLINE AND RECTANGULAR IN SHAPE AND EDGES SHALL BE SQUARE.
- NO SEPARATE PAYMENT WILL BE MADE FOR ROADWAY EXCAVATION OF ANY KIND, INCLUDE ALL COST IN THE VARIOUS ITEMS.
- THE CONTRACTOR SHALL PRESERVE AND PROTECT ALL PROPERTY CORNERS, DURING CONSTRUCTION. ANY PROPERTY CORNERS DISTURBED SHALL BE RESET AT THE EXPENSE OF THE CONTRACTOR.
- THE CONTRACTOR SHALL PROVIDE SLEEVES IN CURB FACE FOR ROOF DRAINS AND SUMP PUMP PIPES WHERE REQUIRED.
- THE CONTRACTOR SHALL CONTACT THE UTILITY COMPANIES TO COORDINATE ANY WORK THAT MAY NEED TO BE CONDUCTED WITHIN THE LIMITS OF WORK.
- THE CONTRACTOR SHALL MAINTAIN EXISTING DRAINAGE PATTERNS IN YARDS AND PRIVATE PROPERTIES ALONG PROPOSED SIDEWALK AND DRIVEWAY INSTALLATIONS.
- HEDGES, BUSHES, LANDSCAPE TIES, STONE EDGING, STONE WALLS, SIGNS, LANDSCAPE MATERIAL, MAILBOXES, FENCES, AND EDGING MATERIAL FOR DRIVEWAYS, SIDEWALKS, AND ROADWAY WIDENING SHALL BE RESET OR REPLACED AS DIRECTED BY THE ENGINEER. NO SEPARATE PAYMENT SHALL BE MADE, INCLUDE ALL COSTS IN THE VARIOUS ITEMS IN THE PROPOSAL. TREE CLEARING AND TRIMMING SHALL BE INCLUDED IN THE COST OF CLEARING SITE.
- THE CONTRACTOR SHALL INSTALL TRAFFIC STRIPES (STOP BARS, AND DOUBLE-YELLOW) AS DIRECTED BY THE ENGINEER.
- ALL TRAFFIC CONTROL SIGNS AND STRIPING SHALL BE IN ACCORDANCE WITH THE M.U.T.C.D. HANDBOOK. EXACT LOCATION AND TYPE OF STREET SIGNS SHALL BE DETERMINED BY ENGINEER.
- ALL TREES ADJACENT TO OR WITHIN THE LIMITS OF WORK ARE NOT TO BE DISTURBED UNLESS OTHERWISE DIRECTED BY THE ENGINEER. THE CONTRACTOR SHALL PROTECT TREES DURING ALL CONSTRUCTION RELATED ACTIVITIES.
- THE TOPSOIL USED FOR THIS PROJECT SHALL BE IN STRICT ACCORDANCE WITH THE PROJECT SPECIFICATIONS. ANY TOPSOIL NOT MEETING WITH THE ENGINEER'S APPROVAL SHALL BE REMOVED AND REPLACED AT CONTRACTOR'S EXPENSE.
- THE CONTRACTOR IS RESPONSIBLE FOR MAKING HIS/HER OWN DETERMINATIONS AS TO THE TYPE AND LOCATION OF UNDERGROUND UTILITIES AS MAY BE NECESSARY TO AVOID DAMAGE THERETO.
- EXISTING UTILITY INFORMATION SHOWN HEREON HAS BEEN COLLECTED FROM VARIOUS SOURCES AND IS NOT GUARANTEED AS TO ACCURACY OR COMPLETENESS. THE CONTRACTOR SHALL VERIFY ALL INFORMATION TO HIS SATISFACTION PRIOR TO EXCAVATION. WHERE EXISTING UTILITIES ARE TO BE CROSSED BY PROPOSED CONSTRUCTION, TEST PITS SHALL BE DUG BY THE CONTRACTOR PRIOR TO CONSTRUCTION TO ASCERTAIN EXISTING INVERTS, MATERIALS AND SIZES. TEST PIT INFORMATION SHALL BE GIVEN TO THE ENGINEER PRIOR TO CONSTRUCTION TO PERMIT ADJUSTMENTS AS REQUIRED TO AVOID CONFLICTS.
- THE CONTRACTOR SHALL NOTIFY THE ENGINEER IMMEDIATELY IF ANY FIELD CONDITIONS ENCOUNTERED DIFFER MATERIALLY FROM THOSE REPRESENTED HEREON.
- ALL MATERIALS, WORKMANSHIP, AND CONSTRUCTION FOR SITE IMPROVEMENTS SHOWN HEREON SHALL BE IN ACCORDANCE WITH N.J. DEPARTMENT OF TRANSPORTATION "STANDARD SPECIFICATIONS FOR ROAD AND BRIDGE CONSTRUCTION", AS CURRENTLY AMENDED.
- THE BASE MAP INDICATING EXISTING CONDITIONS WAS PREPARED BY VALLEE SURVEYING INC.
- CENTERLINE GRADES SHALL MATCH TOP OF CURB ELEVATIONS, UNLESS OTHERWISE NOTED ON THE PLANS OR DIRECTED BY THE ENGINEER.
- CONTRACTOR SHALL PROVIDE A PRE-CONSTRUCTION VIDEO PERFORMED BY A PROFESSIONAL VIDEOGRAPHER.
- IN THE EVENT OF WORK BEING SUSPENDED BY UNSUITABLE WEATHER CONDITIONS, THE CONTRACTOR, AT THEIR EXPENSE, SHALL DO ALL THE WORK NECESSARY TO PROVIDE A SAFE, SMOOTH, WELL DRAINED AND UNOBSTRUCTED PASSAGEWAY THROUGH AND ADJACENT TO THE CONSTRUCTION AREA FOR USE BY THE PUBLIC AND EMERGENCY AND MAINTENANCE VEHICLES DURING THE PERIOD OF SHUT-DOWN.
- CONTRACTOR SHALL MEASURE EXISTING INLET CASTING AND SUBMIT SHOP DRAWINGS FOR ENGINEER'S APPROVAL FOR ECO-GRATES AND CURB PIECES AND SUPPLY AND INSTALL SAME.
- THESE GENERAL NOTES APPLY TO ALL SHEETS IN THIS SET OF PLANS.

**LEGEND, NOTES, AND CONTRACT QUANTITIES**

**IMPROVEMENTS TO HANCE ROAD AND COONEY TERRACE - PHASE 2**

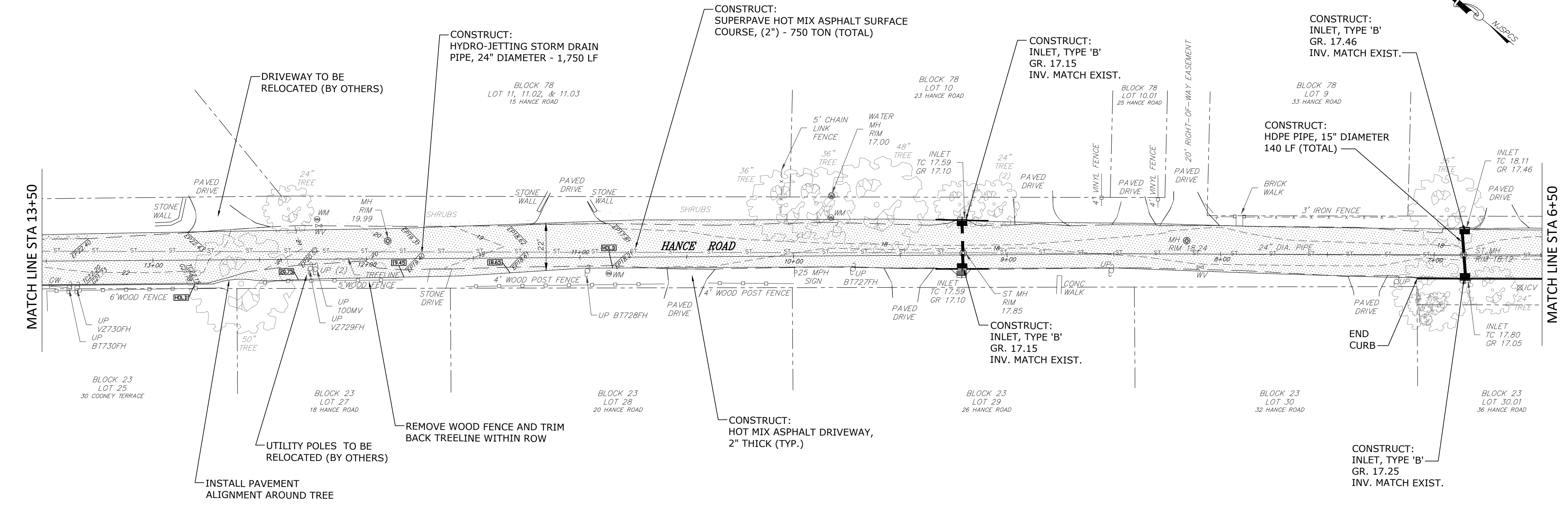
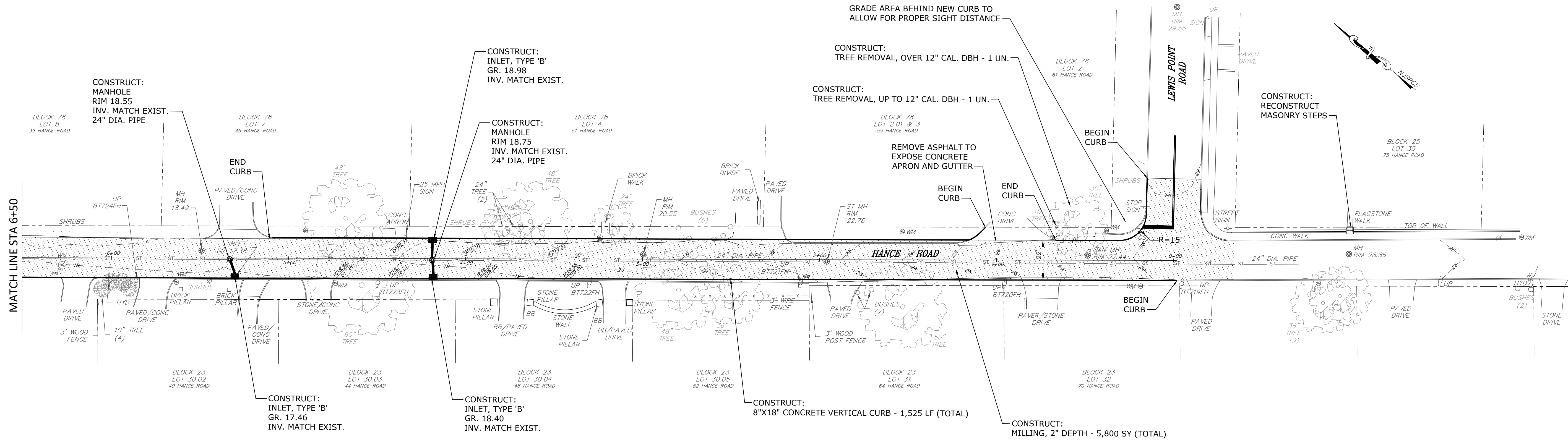
<p><b>BOROUGH OF FAIR HAVEN</b> 748 River Road, Fair Haven, NJ 07704 phone: 732.747.0241 fax: 732.747.6962 website: www.fairhavennj.org</p>	Scale: NONE	Project No. 21-03
	Drawn by: RG	Designed by: RG
<p>Richard Gardella, PE, PP, CME, CPWM PROFESSIONAL ENGINEER New Jersey License No. 43747</p> <p>DATE: 10/25/2021</p>		
Sheet Number: <b>2</b>		of 6



<b>CONSTRUCTION PLAN</b>			
<b>IMPROVEMENTS TO HANCE ROAD AND COONEY TERRACE - PHASE 2</b>			
 <b>BOROUGH OF FAIR HAVEN</b> 748 River Road, Fair Haven, NJ 07704 phone: 732.747.0241 fax: 732.747.6962 website: www.fairhavennj.org	Scale: 1" = 30'	Project No. 21403	
	Drawn by: RG	Designed by: RG	
 <b>RICHARD GARDELLA, PE, PP, CME, CPWM</b> PROFESSIONAL ENGINEER New Jersey License No. 43747		DATE: 10/25/2021	
Sheet Number: <b>3</b>		of 6	

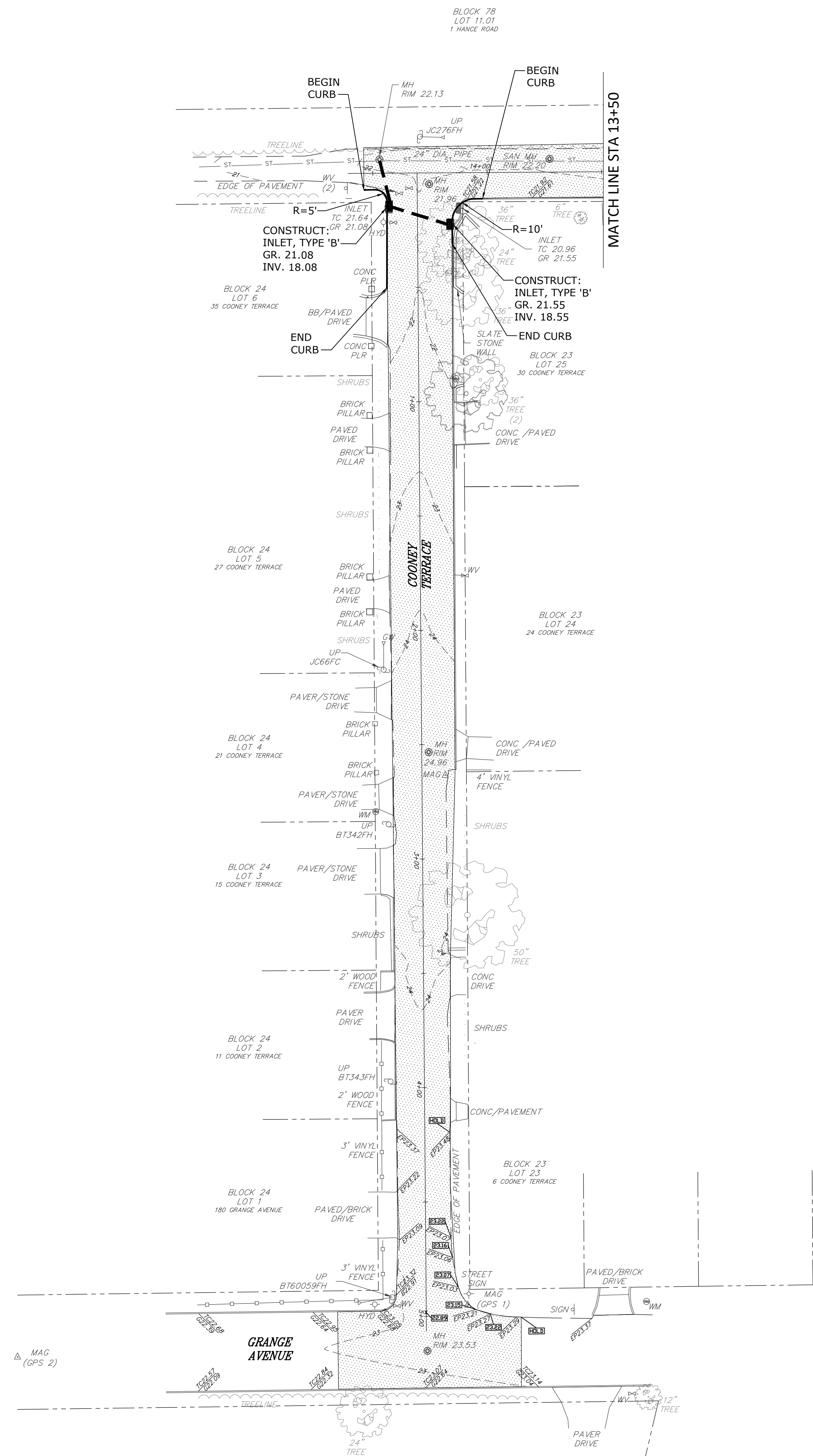

CONSTRUCTION PLAN

IMPROVEMENTS TO HANCE ROAD AND COONEY TERRACE - PHASE 2



BOROUGH OF FAIR HAVEN  
 748 River Road, Fair Haven, NJ 07704  
 phone: 732.747.0241 fax: 732.747.6962  
 website: www.fairhavennj.org

*Richard Gardella*  
 RICHARD GARDELLA, PE, PP, CME, CPWM  
 PROFESSIONAL ENGINEER  
 New Jersey License No. 43747

DATE: 10/25/2021

Scale: 1" = 30'  
 Project No. 21-03

Drawn by: RG  
 Designed by: RG

Sheet Number: 4  
 of 6

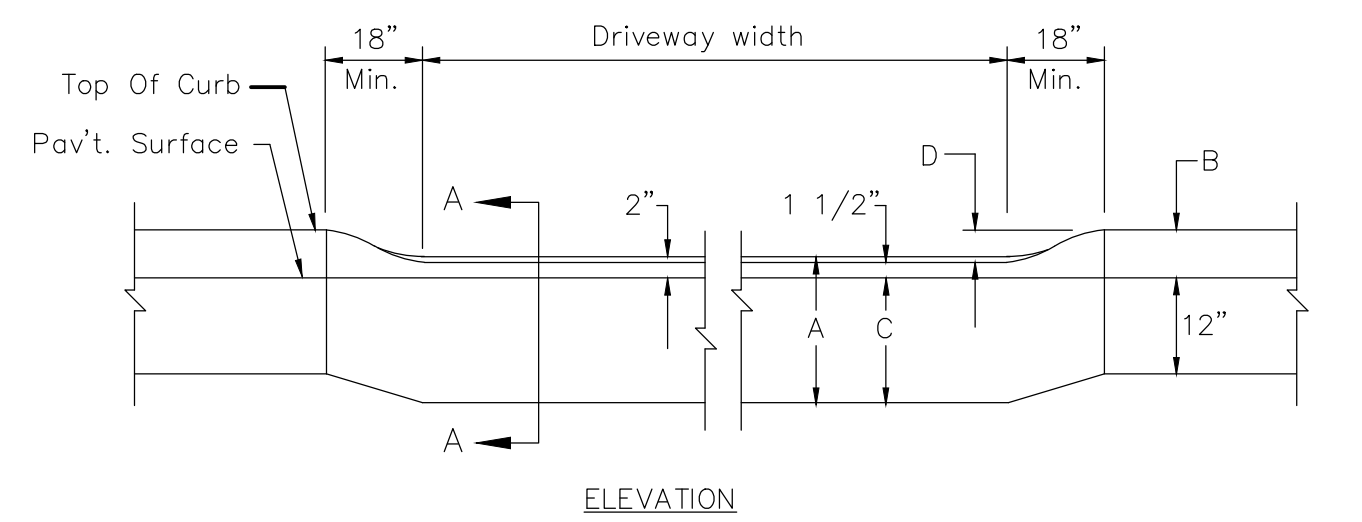

CURB SIZE	DIM. A	DIM. B	DIM. C	DIM. D	DIM. E
8" X 18"	18"	6"	16"	4 1/2"	8"
8" X 20"	20"	8"	18"	6 1/2"	8"

**METHOD OF DEPRESSING CURB AT DRIVEWAYS**  
NOT TO SCALE

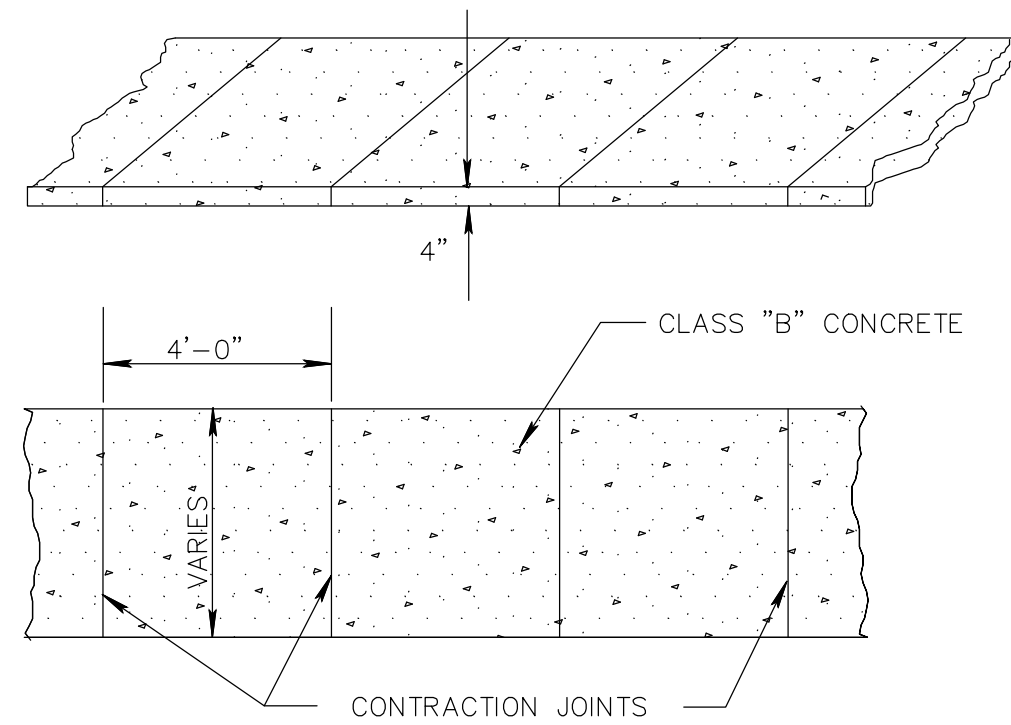

**TYPICAL DETAIL CONCRETE SIDEWALK**  
NOT TO SCALE

**NOTES:**

1. PREFORMED BITUMINOUS EXPANSION JOINTS, 1/2" THICK SHALL BE INSTALLED EVERY 20 FEET. CONTRACTION JOINTS SHALL BE INSTALLED EVERY 4 FEET.
2. CONCRETE SHALL BE CLASS "B" PORTLAND CEMENT HAVING A 28 DAY STRENGTH OF 4000 PSI.

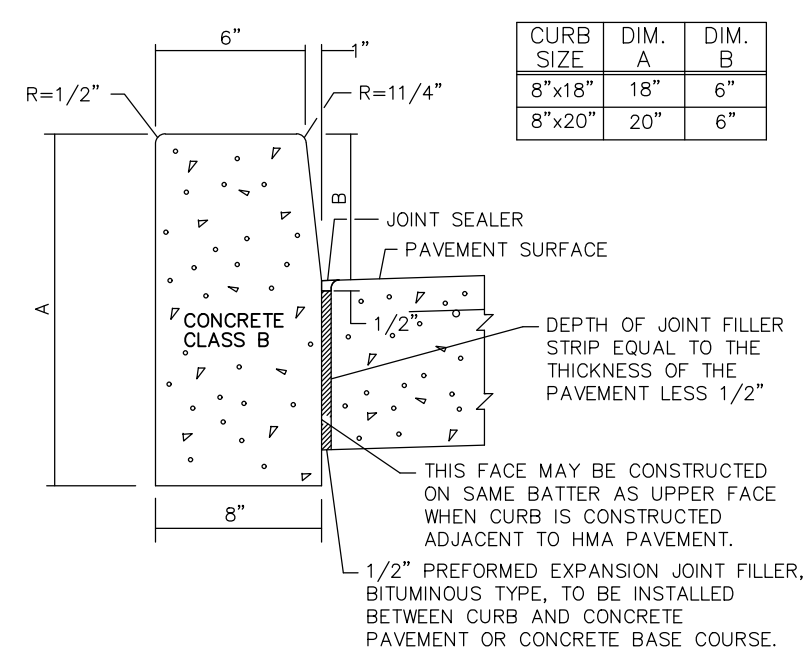

**CONCRETE VERTICAL CURB**  
NOT TO SCALE

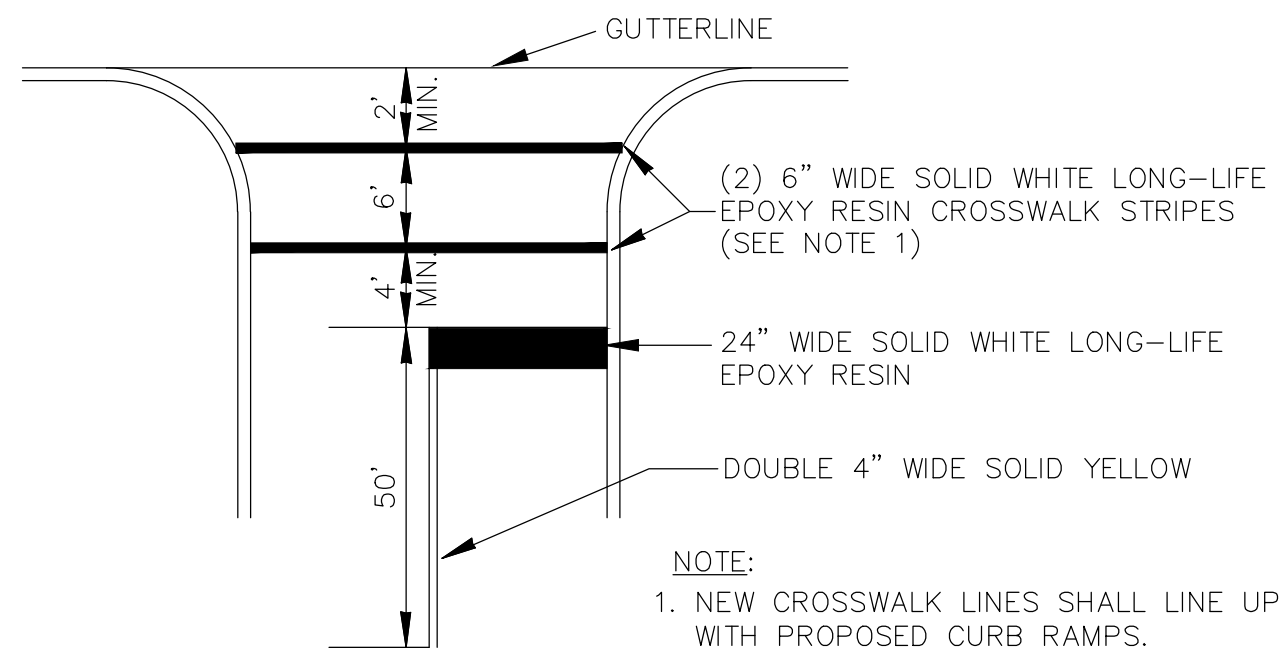

**CROSSWALK AND STOP LINE STRIPING DETAIL**  
NOT TO SCALE

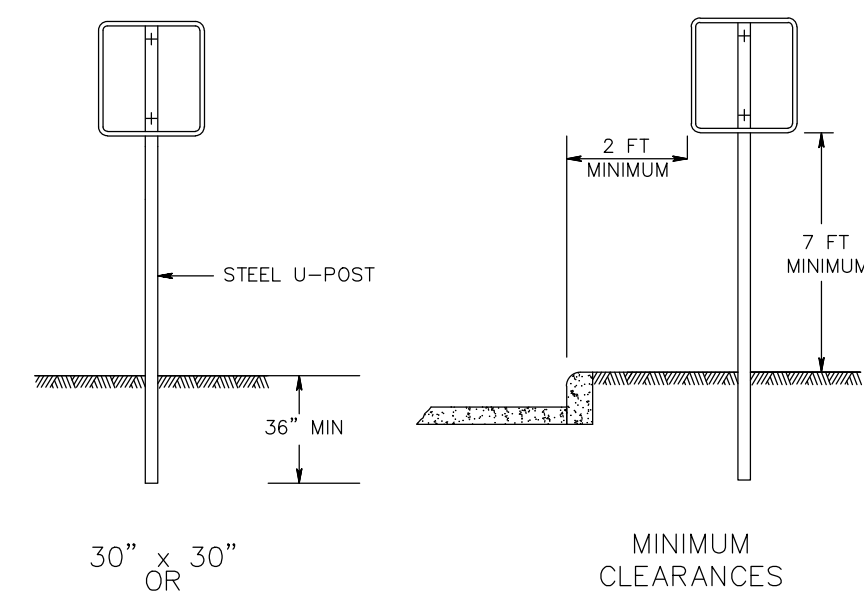

**SIGNS**  
NOT TO SCALE

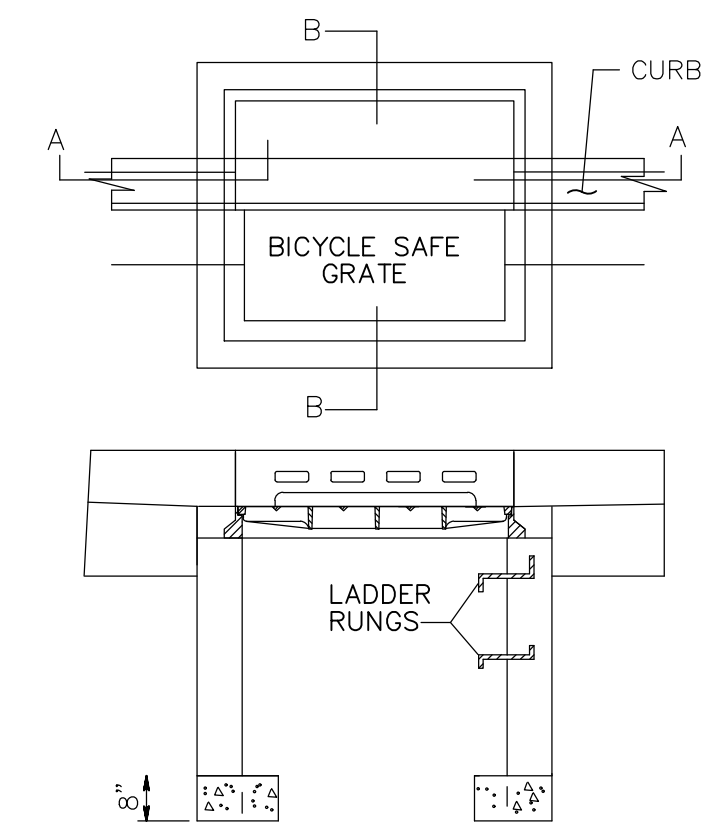

**SECTION A-A**

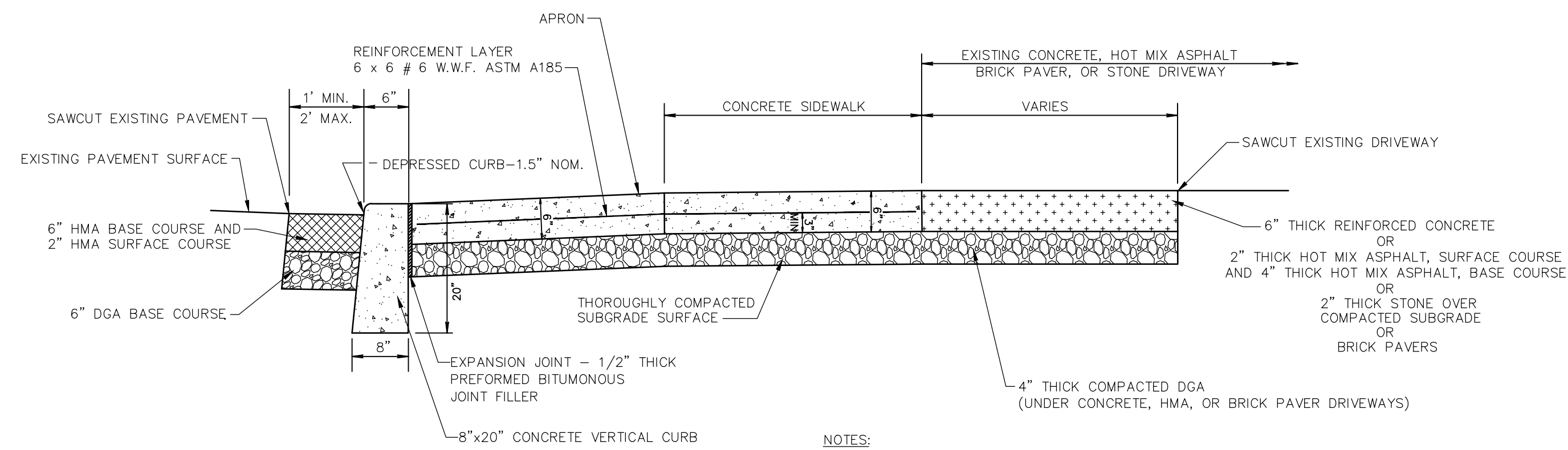

- NOTES:**
1. CONCRETE SHALL BE 4,000 P.S.I. AT 28 DAYS.
  2. CONCRETE APRON SHALL BE EVENLY DIVIDED WITH EXPANSION JOINTS SUCH THAT NO PANEL EXCEEDS 20' IN ANY DIMENSION.
  3. NO SEPARATE PAYMENT SHALL BE MADE FOR PAVEMENT REPAIR ALONG NEW CURBS. INCLUDE ALL COSTS IN THE PAY ITEM '8"x18" CONCRETE VERTICAL CURB'.

**CONCRETE DRIVEWAY, REINFORCED, 6" THICK AND DRIVEWAY RESTORATION**  
NOT TO SCALE

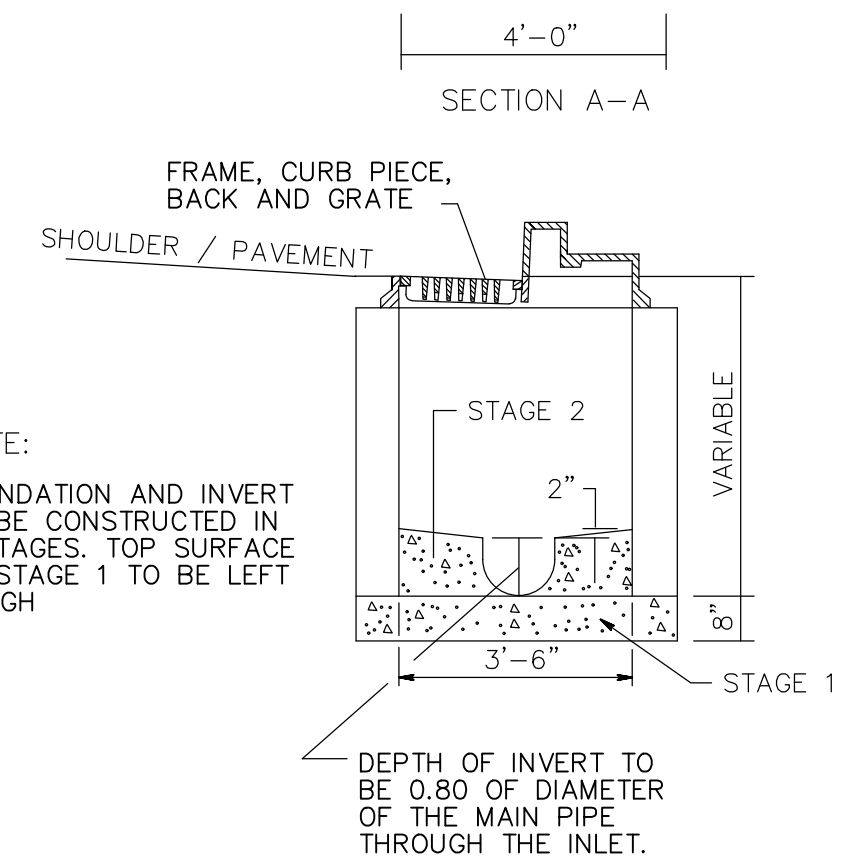

**INLET, TYPE 'B'**  
NOT TO SCALE

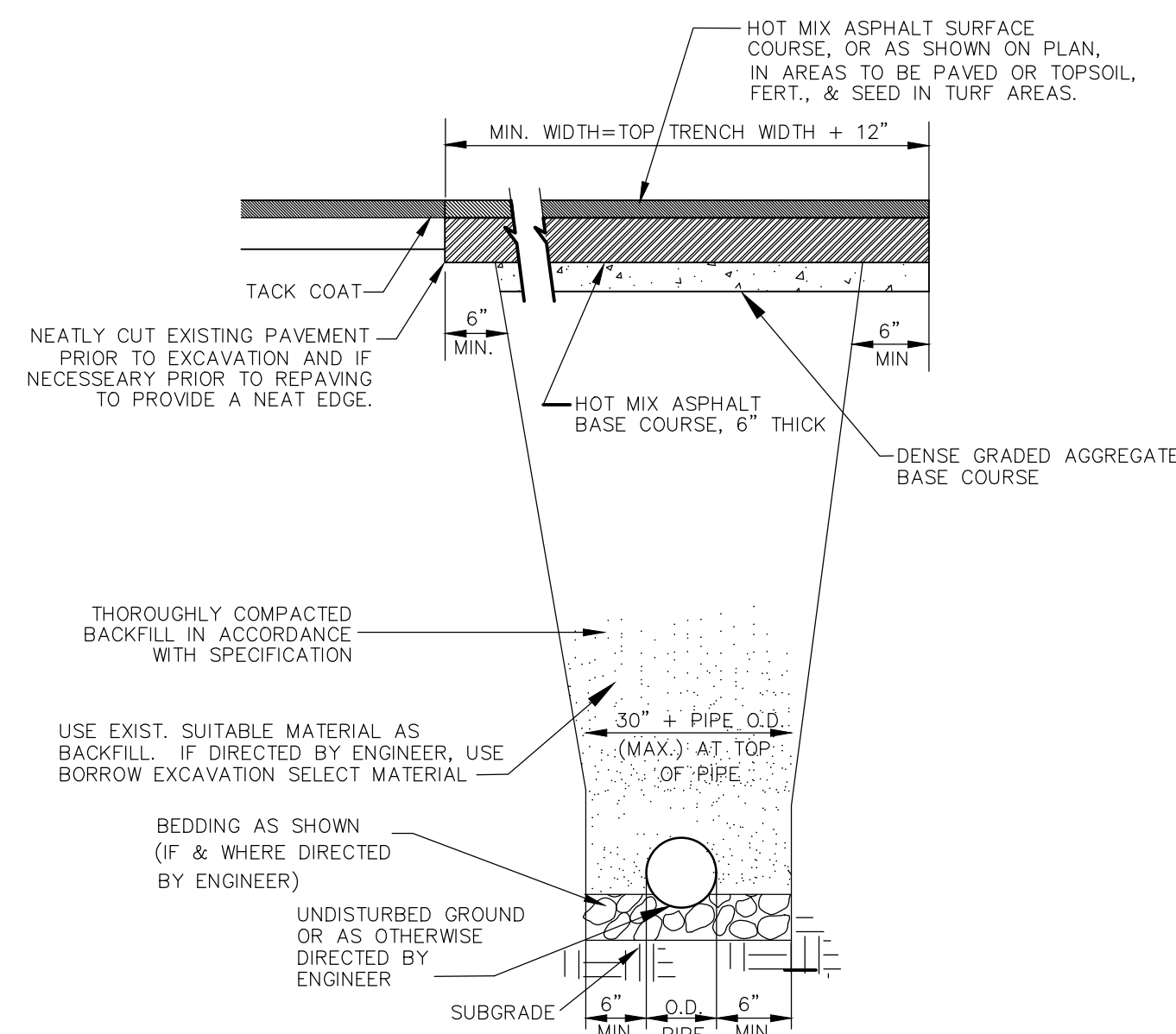

- CONSTRUCTION NOTES:**
- TEMPORARY PAVEMENT OF 6" THICK DGA AND 6" THICK HMA BASE COURSE TO BE MAINTAINED FOR A MINIMUM OF 60 DAYS PRIOR TO OVERLAY.

**TRENCH REPAIR**  
NOT TO SCALE

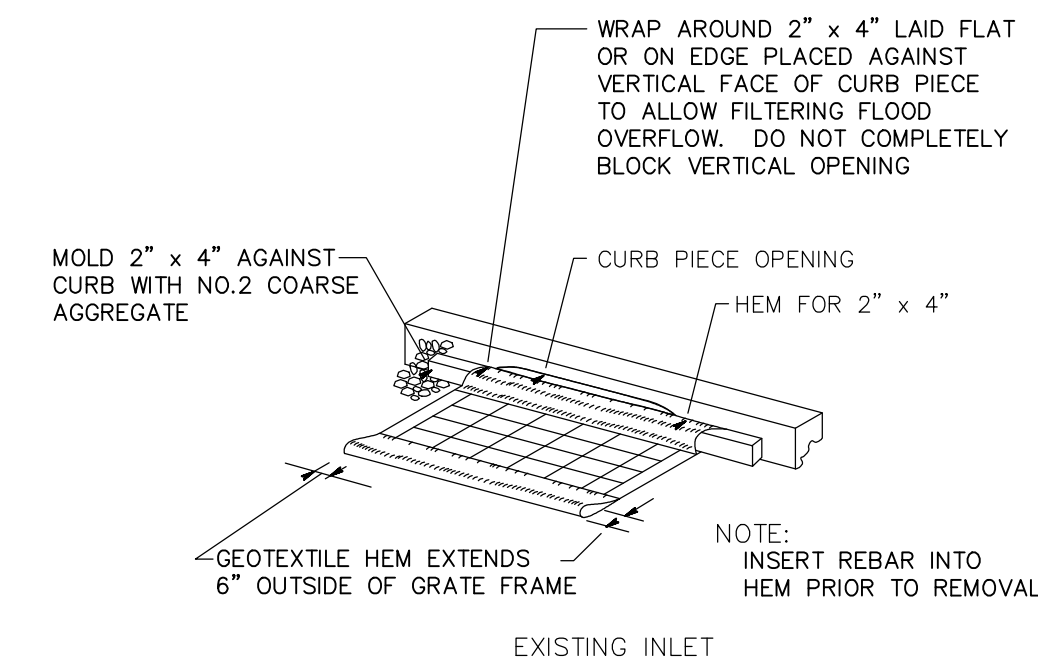

**EXISTING INLET**

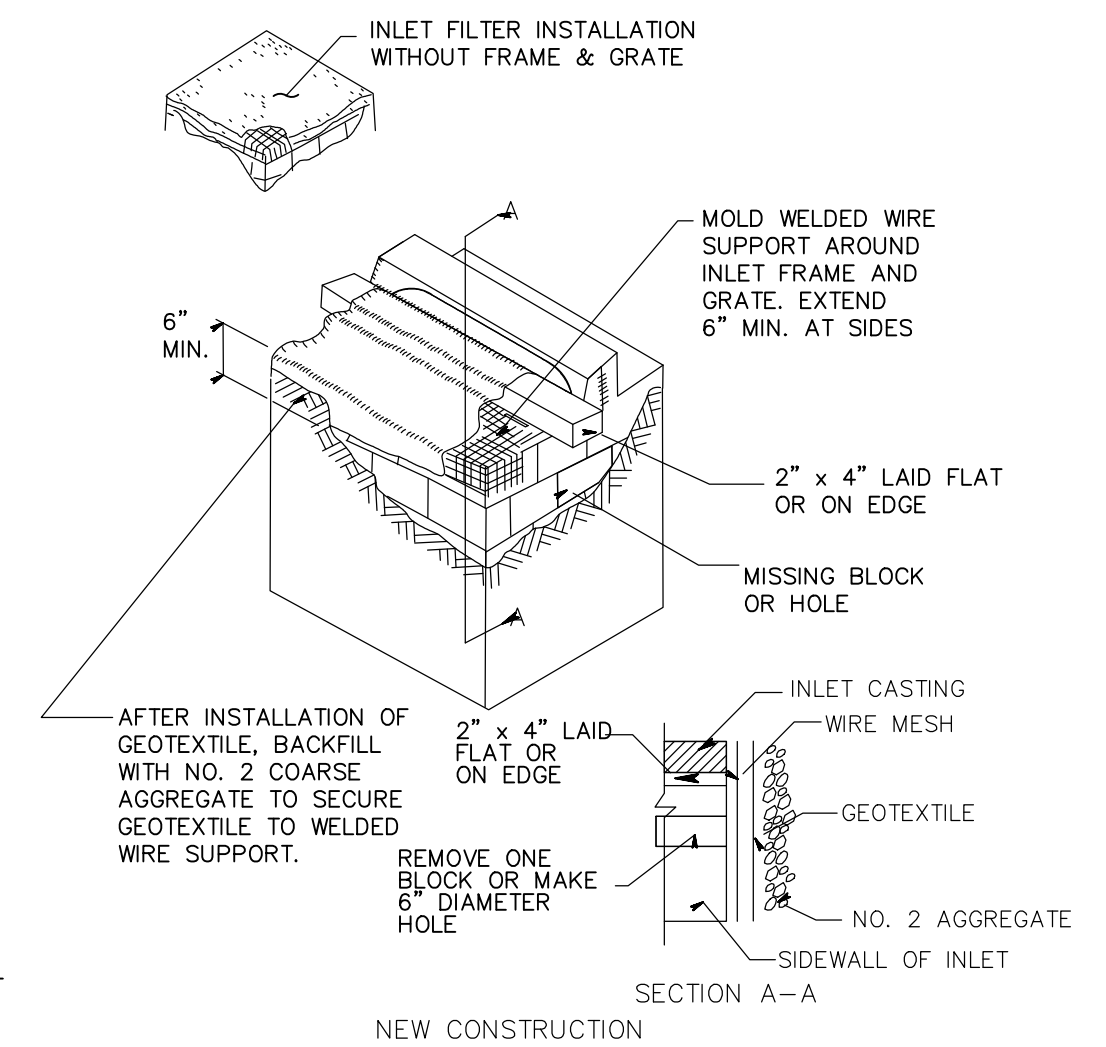

**INLET FILTER, TYPE 2**  
NOT TO SCALE

<b>CONSTRUCTION DETAILS</b>			
<b>IMPROVEMENTS TO HANCE ROAD AND COONEY TERRACE - PHASE 2</b>			
	<b>BOROUGH OF FAIR HAVEN</b> 748 River Road, Fair Haven, NJ 07704 phone: 732.747.0241 fax: 732.747.6962 website: www.fairhavennj.org		Scale: NONE Project No: 21-03
	Drawn by: RG		Designed by: RG
Sheet Number: <b>5</b> <small>of 6</small>			DATE: 10/25/2021 RICHARD GARDELLA, PE, PP, CME, CPWM PROFESSIONAL ENGINEER New Jersey License No. 43747

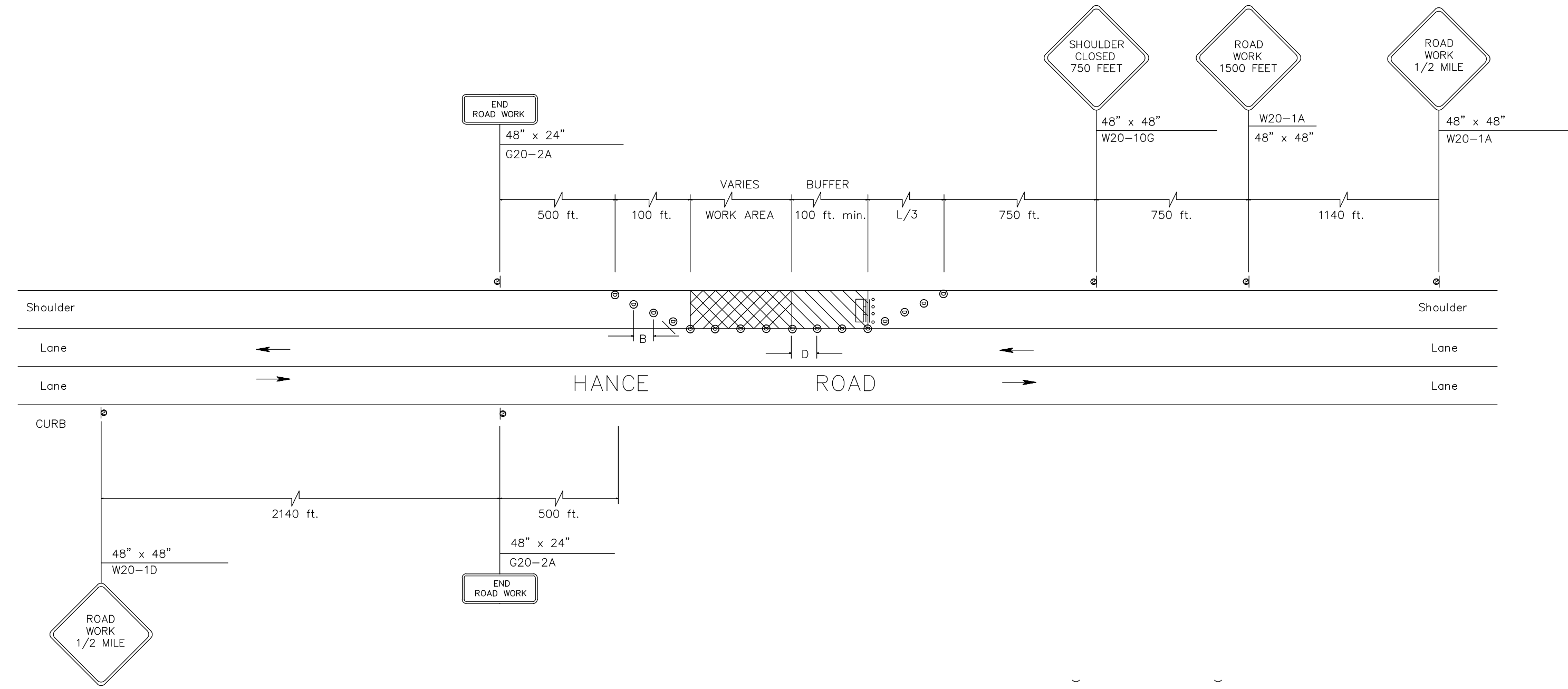

2 LANES, SHOULDER CLOSING – HANCE ROAD  
NOT TO SCALE

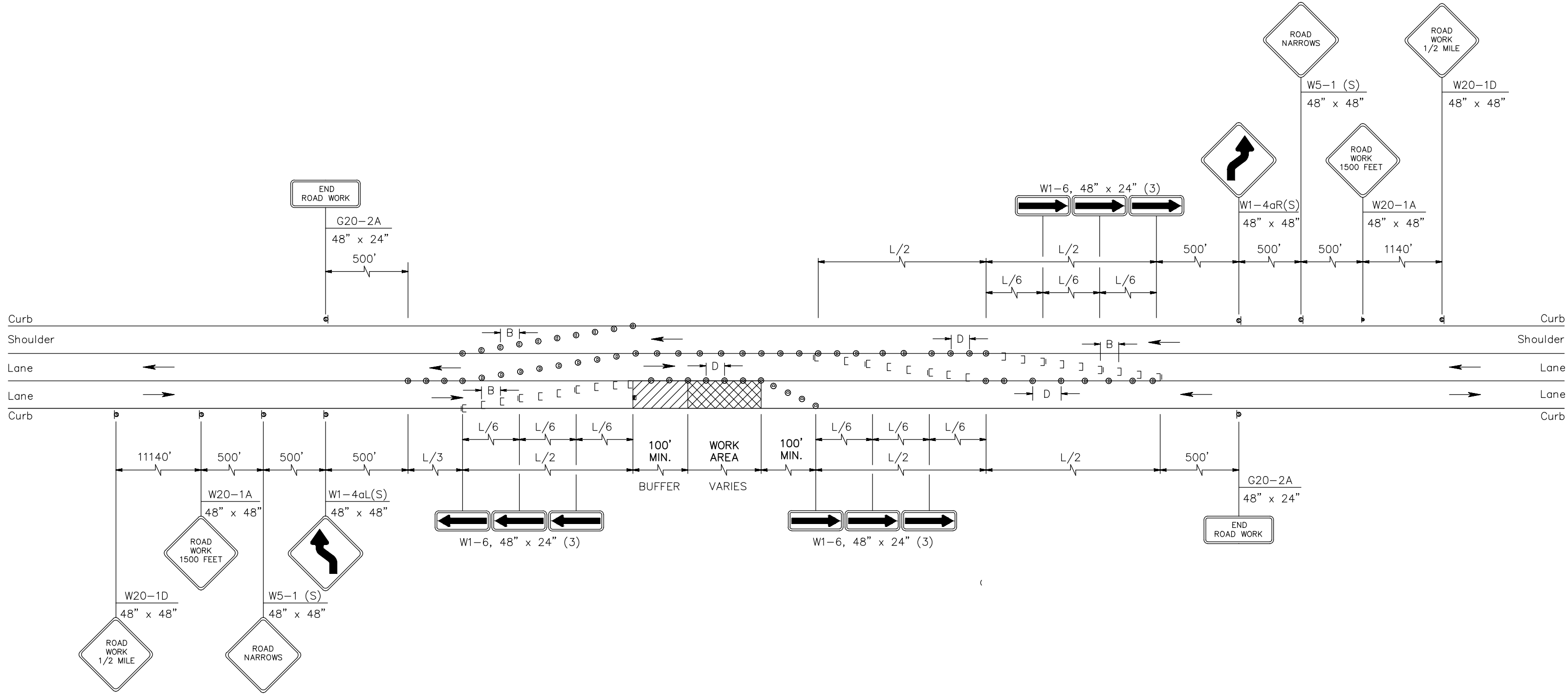

2 LANES, LANE & SHOULDER CLOSING – HANCE ROAD  
NOT TO SCALE

LEGEND

- BREAKAWAY BARRICADE
- BREAKAWAY BARRICADES WITH SIGN
- CONSTRUCTION SIGNS
- DRUM
- ◇ TRAFFIC CONE
- PRECAST CONCRETE CURB CONSTRUCTION BARRIER (TYPE SPECIFIED)
- ← DIRECTION OF TRAFFIC FLOW
- TRAFFIC DIRECTOR, FLAGGER
- TRAILER MOUNTED MOUNTED ARROW BOARD SHOWING CAUTION MODE
- ↑ ILLUMINATED FLASHING ARROW MOUNTED ON TOWING VEHICLE SHOWING ARROW PATTERN (Left, Right, Both)
- ↑ LEFT ↑ RIGHT ↑ BOTH
- ↑ TRAFFIC CONTROL TRUCK WITH MOUNTED CRASH CUSHION
- ↑ TRAFFIC CONTROL TRUCK WITH MOUNTED CRASH CUSHION AND ARROW BOARD SHOWING ARROW PATTERN (Left, Right, Both)
- ↑ LEFT ↑ RIGHT ↑ BOTH
- TEMPORARY CRASH CUSHION, INERTIAL BARRIER SYSTEM
- TEMPORARY CRASH CUSHION, (all other approved)
- BUFFER ZONE
- WORK AREA
- PAINT STRIPING TRUCK OR OTHER OPERATING VEHICLE

GENERAL NOTES:

1. ADVANCE WARNING SIGNS DISTANCES, AND TAPER LENGTHS MAY BE EXTENDED, AT DIRECTION OF THE DEPARTMENT, TO ADJUST FOR REDUCED VISIBILITY DUE TO HORIZONTAL AND VERTICAL CURVATURE OF THE ROADWAY.
2. THE APPROXIMATE LOCATIONS OF THE ILLUMINATED FLASHING ARROW BOARDS ARE SHOWN ON THE TRAFFIC CONTROL PLANS. THESE LOCATIONS MAY BE MODIFIED AS APPROVED BY THE RE. TO ADJUST FOR VISIBILITY DUE TO HORIZONTAL OR VERTICAL CURVATURE OF THE ROADWAY OR TO POSITION AT A SAFER LOCATION. ILLUMINATED FLASHING ARROW BOARDS ARE TO BE USED FOR TEMPORARY LANE CLOSINGS AND AT LOCATIONS SHOWN ON THE TRAFFIC CONTROL PLANS.
3. PRIOR TO ANY ROAD CONSTRUCTION, TRAFFIC CONTROL SIGNS AND DEVICES SHALL BE IN PLACE.
4. RAMPS AND/OR SIDE STREETS ENTERING THE ROADWAY AFTER THE FIRST ADVANCE WARNING SIGN SHALL BE PROVIDED WITH AT LEAST ONE W20-IF SIGN (ROAD WORK AHEAD) AS A MINIMUM.
5. ALL EXISTING ROAD SIGNS, PAVEMENT MARKINGS AND/OR REMOVABLE PAVEMENT REFLECTORS WHICH CONFLICT WITH THE PROPOSED TRAFFIC CONTROL PLAN SHALL BE COVERED, REMOVED OR RELOCATED AS DIRECTED BY THE RE.
6. CONFLICTING OR NON-OPERATING SIGNAL INDICATIONS ON EITHER THE EXISTING, TEMPORARY OR PROPOSED TRAFFIC SIGNAL SYSTEMS SHALL BE BAGGED OR COVERED.
7. MAINTENANCE AND PROTECTION OF TRAFFIC SHALL BE IN ACCORDANCE WITH THE MANUAL OF UNIFORM TRAFFIC CONTROL DEVICES – PART VI "STANDARDS AND GUIDES FOR TRAFFIC CONTROL FOR STREET AND HIGHWAY CONSTRUCTION, MAINTENANCE, UTILITY, AND INCIDENT MANAGEMENT OPERATIONS", UNLESS OTHERWISE NOTED IN THE PLANS AND SPECIFICATIONS.
8. CONSTRUCTION SIGN W99-2 (GIVE US A BRAKE) SHALL BE LOCATED 200 FEET IN ADVANCE OF PROJECT LIMITS.
9. A W1-6 (ARROW) SIGN MOUNTED ON A BREAKAWAY BARRICADE AND CENTERED ON THE CLOSED WIDTH SHALL BE LOCATED 100 FEET BEYOND EACH INTERSECTION OR MAIN ACCESS POINT WITHIN THE AREA OF A LANE OR SHOULDER CLOSURE.
10. CONSTRUCTION SIGNS R11-4 (ROAD CLOSED TO THRU TRAFFIC) SHALL BE PLACED AT THE INTERSECTING STREETS WHICH ARE CLOSED TO TRAFFIC BECAUSE OF CONSTRUCTION.
11. CONSTRUCTION SIGNS W8-9A (SYMBOL FOR UNEVEN PAVEMENT) AND W8-14A (GROOVED PAVEMENT) SHALL BE USED WHEN SUCH PAVEMENT CONDITIONS EXIST. THE PLACEMENT OF THESE SIGNS SHALL BE AS DIRECTED BY THE RE.
12. MOVING WORK AREAS IN A LANE CLOSURE REQUIRE A TRAILER MOUNTED ILLUMINATED FLASHING ARROW TO REMAIN AT THE END OF THE TAPER, THE TRAFFIC CONTROL TRUCK WITH MOUNTED CRASH CUSHION THAT SHALL MOVE WITH THE WORK AREAS TO KEEP A 70 FEET MIN. AND 150 FEET MAX. BUFFER IN ADVANCE OF EACH WORK AREA.
13. THE CONTRACTOR SHALL SUBMIT A PLAN FOR THE SAFE ACCESS OF CONSTRUCTION VEHICLES THROUGHOUT THE WORK SITE WHERE SPACE CONSTRAINTS PREVENT THE USE OF LANE CLOSURES. THE PLAN SHALL BE SUBMITTED TO THE RE IN ACCORDANCE WITH THE STANDARD SPECIFICATIONS.
14. ALL EXCAVATED AREAS WITHIN OR ADJACENT TO THE ROADWAY SHALL BE BACKFILLED AND PLACED ON AT LEAST 1:1V SLOPE BEFORE THE END OF EACH WORK DAY. OTHER EXCAVATED AREA WITHIN THE CLEAR ZONE SHALL BE BACKFILLED.
15. WHERE REQUIRED, THE CONTRACTOR SHALL MAKE PROVISIONS FOR MAINTAINING PEDESTRIAN CROSSING LOCATIONS AND TYPE AS DIRECTED BY THE RE.
16. BITUMINOUS CONCRETE PLACED DURING THE VARIOUS CONSTRUCTION STAGES SHALL BE TRANSITIONED ON A MINIMUM 20H : 1V SLOPE TO MEET THE ADJACENT EXISTING GRADE AT THE LONGITUDINAL AND TRANSVERSE LIMITS OF THE STAGE CONSTRUCTION AREAS UNLESS OTHERWISE NOTED ON THE STAGE CONSTRUCTION PLANS.
17. THE PLACEMENT AND OR RELOCATION OF PRECAST CONCRETE CURB, CONSTRUCTION BARRIER SHALL BE DONE DURING APPROVED OFF-PEAK HOURS WHEN TRAFFIC MAY BE REDUCED TO ONE LANE IN EACH DIRECTION.
18. THE REDUCED SPEED AHEAD SIGN, W3-5(S) (BLACK ON ORANGE) SHALL BE LOCATED IN ADVANCE OF SPEED LIMIT R2-1 SIGNS WHICH REDUCE THE NORMAL POSTED SPEED LIMIT THROUGH THE CONSTRUCTION ZONE.
19. TRAFFIC FINES DOUBLED IN WORK AREA R(N)5-17(S), 4 FEET BY 2.5 FEET SIGN SHALL BE LOCATED 500 FEET AFTER THE FIRST ADVANCE WARNING SIGN, (W20 SERIES) AT EACH WORK AREA LOCATED WITHIN URBAN AREAS. THIS SIGN SHALL ALSO BE USED ON PROJECTS REQUIRING MOVING OPERATIONS IN WHICH CASE THE SIGN SHALL BE MOUNTED ON A SLOW MOVING CONSTRUCTION VEHICLE.
20. THE FINAL HMA SURFACE PAVEMENT SHALL NOT BE CONSTRUCTED UNTIL THE FINAL STAGE OF THE PROJECT UNLESS OTHERWISE DIRECTED BY THE RE OR INDICATED ON THE PLANS, MANHOLES AND INLETS SHALL BE SET TO FINISHED GRADE AND TEMPORARY PAVEMENT RAMPS ARE TO BE CONSTRUCTED AROUND THEM WITH A MINIMUM 20H : 1V SLOPE IN ALL DIRECTIONS USING HOT MIX ASPHALT PAVEMENT. THIS TEMPORARY MATERIAL WILL BE REMOVED IMMEDIATELY PRIOR TO PLACING THE SURFACE COURSE.

DRUMS SHALL BE MADE OF ORANGE PLASTIC WITH A MINIMUM OF FOUR ALTERNATE FLUORESCENT ORANGE AND WHITE RETROREFLECTIVE STRIPES. IF THERE ARE NON-REFLECTORIZED SPACES BETWEEN THE STRIPES, THEY SHALL BE NO MORE THAN 2" WIDE. RETROREFLECTIVE SHEETING FOR STRIPES SHALL CONFORM WITH ASTM D 4956 TYPE VI OR VII WITH S2 REQUIREMENTS.

THE TOP OF THE DRUM SHALL NOT BE OPEN. DRUMS SHALL BE CONSTRUCTED TO INHIBIT ROLLING IF KNOCKED OVER.

THE REFLECTORIZED AREA OF DRUMS SHALL BE ROUND EXCEPT THAT OTHER SHAPES, WHICH PROVIDE THE SAME VISIBILITY AS AN 18 INCH DIAMETER ROUND DRUM REGARDLESS OF ORIENTATION, MAY BE USED.

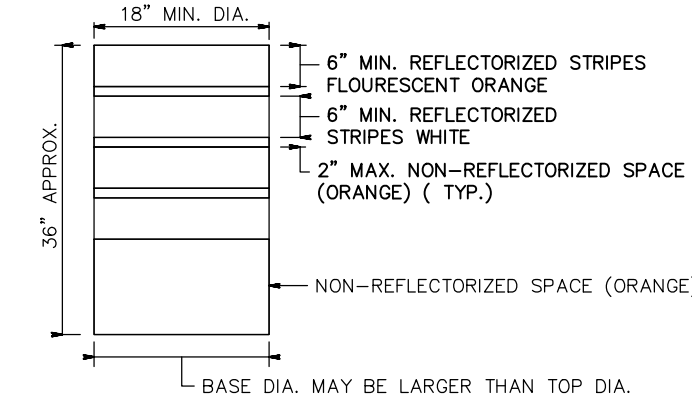

WHEN BALLAST IS REQUIRED BY THE RE, SAND SHALL BE USED. THE MAXIMUM WEIGHT OF THE BALLAST SHALL BE 50 LBS. AND BE LOCATED APPROXIMATELY AT GROUND LEVEL. ALTERNATE TYPES OF BALLAST SHALL BE APPROVED BY THE RE.

DRUMS

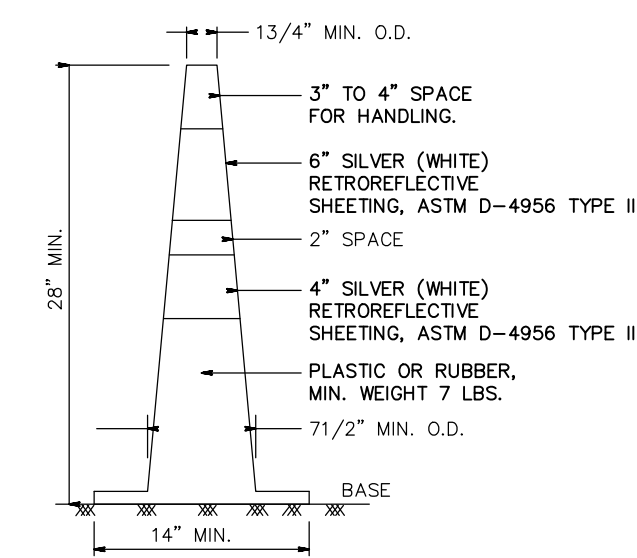

TRAFFIC CONES

- NOTES:
- TRAFFIC CONES SHALL BE PREDOMINATELY ORANGE IN COLOR.
- BASES MAY BE OF BREAKAWAY BALLASTED TYPE.
- MINOR MANUFACTURER'S VARIATIONS MAY BE ACCEPTABLE UPON APPROVAL OF THE ENGINEER.

REGULATORY APPROACH SPEED OF TRAFFIC MILES/HOUR	RECOMMENDED TAPER LENGTH AND SPACING FOR CHANNELIZING TAPERS			RECOMMENDED SPACING ALONG TANGENTS	
	MINIMUM TAPER RATIO	MINIMUM TAPER LENGTH L – FOR LANE WIDTHS	MAXIMUM DEVICE (B) SPACING ALONG TANGENTS IN FEET		
25	18.5:1	105	115	125	25
30	15:1	150	165	180	30
35	20.5:1	205	225	245	35
40	27:1	270	300	325	40
45	45:1	450	495	540	45
50	50:1	500	550	600	50
55	55:1	550	605	660	55
60	60:1	600	660	720	60
65	65:1	650	715	780	65

NOTE: THE MAXIMUM DEVICE SPACING ALONG CURVES SHALL BE AS DEFINED FOR TAPERS (B) IN THE ABOVE TABLE.



W20-1  
48" X 48"  
16 S.F.  
SIGN "A"



48" X 24"  
SIGN "B"

TRAFFIC CONTROL PLAN AND NOTES

IMPROVEMENTS TO HANCE ROAD AND COONEY TERRACE - PHASE 2



BOROUGH OF FAIR HAVEN  
748 River Road, Fair Haven, NJ 07704  
phone: 732.747.0241 fax: 732.747.6962  
website: www.fairhavennj.org

Scale: 1"=30'  
Project No: 21-03  
Drawn by: RG  
Designed by: RG



RICHARD GARDELLA, PE, PP, CME, CPWM  
PROFESSIONAL ENGINEER  
New Jersey License No. 43747

DATE: 10/25/2021

Sheet Number: 6  
of 6